

MANUAL

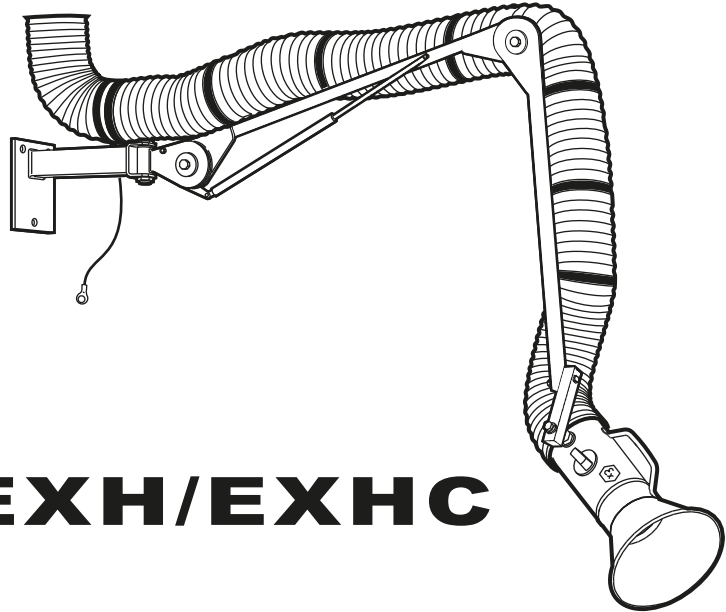

R EXH/EXHC

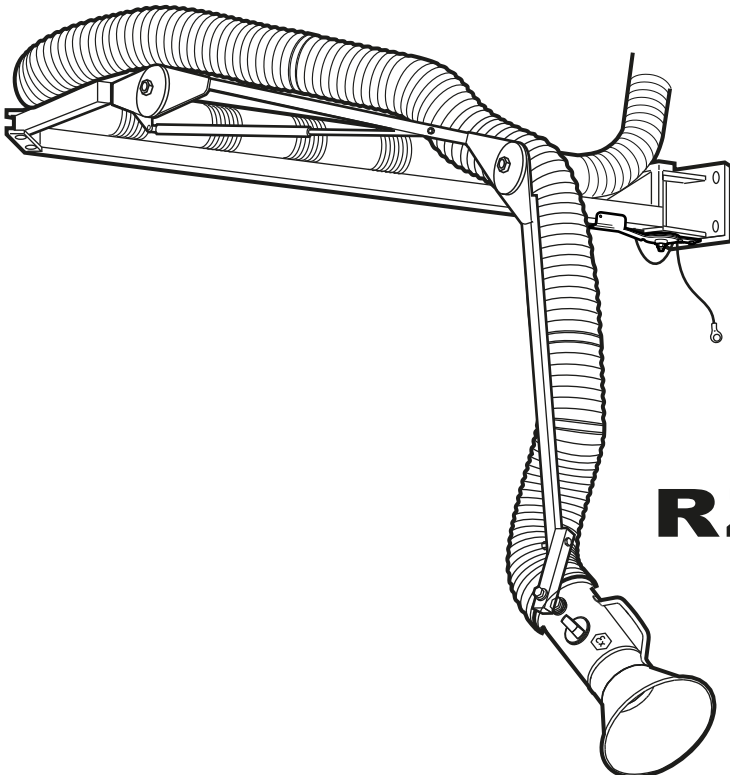

RZ EXH/EXHC

MOVEX[®]

Contents

| | |
|-----------------------------------|------|
| IMPORTANT INFORMATION | 3 |
| APPLICATIONS | 3 |
| TECHNICAL DATA | 4 |
| INSTALLATION AND USE | 5-7 |
| CLEANING | 8 |
| SERVICE AND REPAIRS | 8 |
| SPARE PARTS AND ACCESSORIES | 9-11 |
| TESTING AND TROUBLESHOOTING | 12 |
| LOG BOOK FOR MEASURING RESISTANCE | 12 |

Important information

NOTE: Read the instructions carefully before installing and using this equipment.

The local extractor in the R/RZ EXH/EXHC series is designed to meet the requirements in the ATEX directive 2014/34/EU, applicable to equipment intended for use in potentially explosive atmospheres. In order to maintain explosion proof integrity, you must observe the instructions in this manual. Only personnel with the right qualifications may handle this equipment when installing or for service and repairs. Only use original spare parts when repairing the equipment in order to maintain explosion proof integrity. Contact your nearest dealer or head office when purchasing spare parts or if you have technical queries.

Note that all other equipment in the explosively hazardous environment must also be intended for use in this environment to avoid any risk of explosion.

Applications

The local extraction in the R/RZ EXH/EXHC series is intended for use in environments where the atmosphere may be explosive as a result of air and gas mixtures, mist, steam or dust, in otherwise normal circumstances as regards temperature and air pressure. The equipment thereby meets the requirements for equipment category 2 for gas and dust, which means that it is suitable for use in zones 1 or 21, where gas or dust can sometimes be expected to occur. This means that the equipment is also suitable for use in zones 2 or 22, where gas or dust occurs only occasionally.

Do not use the equipment in environments where there are substances that attack or react with the material it consists of, see material specification in "Technical data", as such substances may degrade the explosion proof integrity of the equipment or cause a risk of explosion when reacting. If in doubt, contact your nearest dealer or head office.

The equipment should not be used for non-conductive dust with $MIE < 4$ mJ if there is a risk that the dust is, or could become, highly charged (MIE = Minimum Ignition Energy). Do not hang objects or suchlike on the arm as it is not designed for such purposes. Note that the proprietor is responsible for the classification and zone division of the workplace.

Technical data

| | |
|--|------------------------------|
| Suitable for use in zone | 1, 2 (gas) och 21, 22 (dust) |
| Rec. ambient temperature | +50°F till +120°F |
| Rec. air velocity to avoid dust accumulation | 3500 – 5000 feet/minute |
| Dimensions of hose/ suction head | Ø4", 5", 6" and 8" |

Material R/RZ EXH/EXHC:

| | |
|----------------------------|-----------------|
| Arm system | Stainless steel |
| Wall and ceiling bracket | Stainless steel |
| Suction head | Stainless steel |
| Damper blade | Stainless steel |
| Anchor for attaching strap | Polyamide |

Other material:

| | |
|-----------------|--------------------------------------|
| Gas spring | Stainless steel |
| Attachment | Stainless steel |
| Bearing | Stainless steel |
| Hose clamp | Stainless steel |
| Hose - EXH | Conductive PU hose $R < 10^9 \Omega$ |
| Hose - EXHC | Conductive PE hose $R < 10^4 \Omega$ |
| Friction washer | PTFE-coated steel |
| Friction disk | Asbestos free friction material |
| Mounting strap | Polyamide 6/6 |
| Damper knob | Conductive PA, $R < 10^6 \Omega$ |
| End plug | Polyethylene |

Installation and use

The equipment can be delivered partially assembled and installed as per the following description. The equipment can be mounted on a wall or to the ceiling using special brackets, see "Spare parts and accessories". Measure a suitable height for the bracket before mounting the arm to the wall, and check that the existing air duct reaches the hose when fitting to the ceiling, see figures.

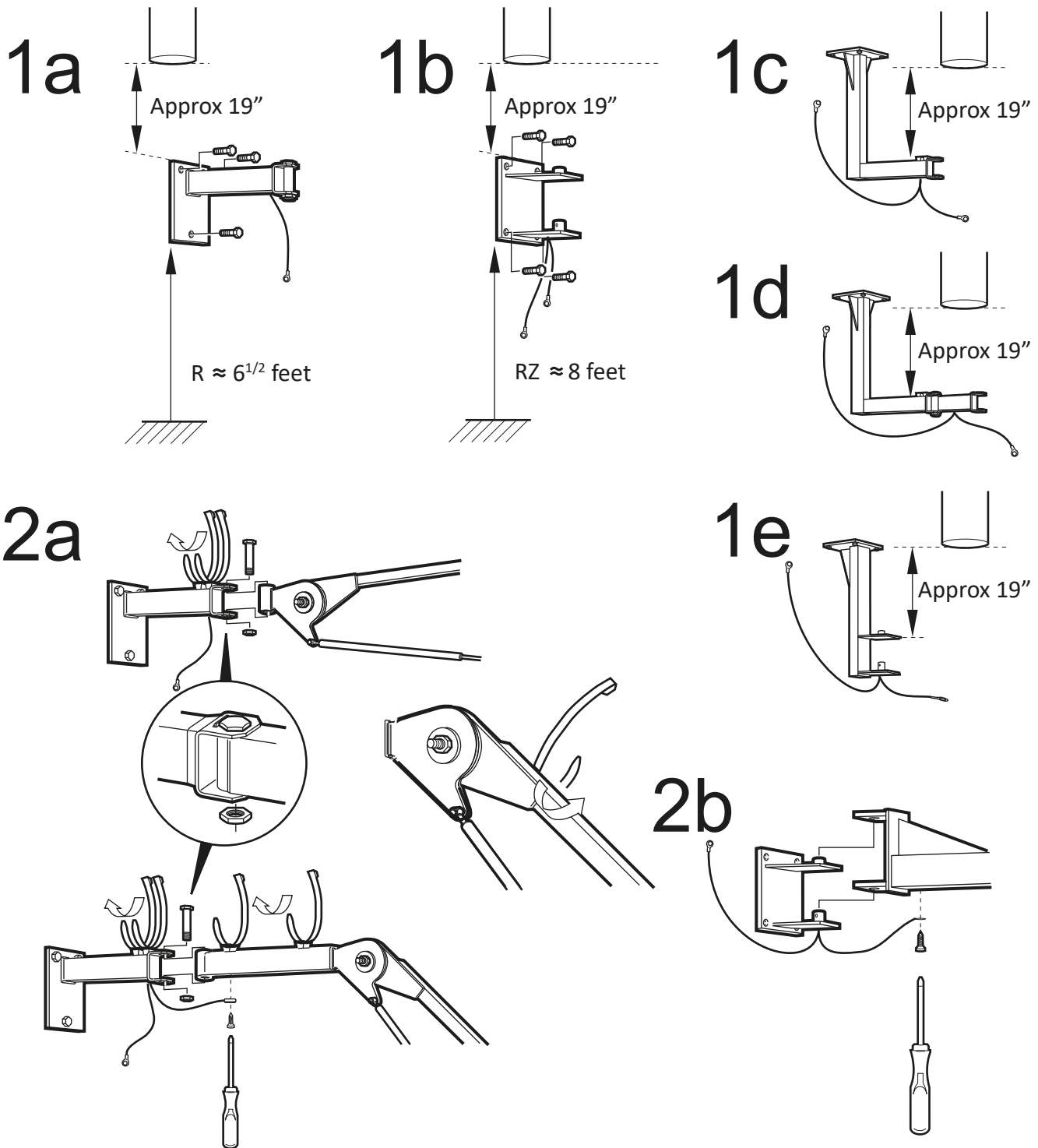

- 1) Fit the wall bracket a) R EXH/EXHC, b) RZ EXH/EXHC
- 1) Fit the ceiling bracket c) and d) R EXH/EXHC, e) RZ EXH/EXHC
- 2a) Screw the arm to the bracket, fit the tie strap in anchor (R EXH/EXHC). Screw in the shorter connection cable's loose end into the friction joint (For R 4000 EXH/EXHC)
- 2b) Hang the inner RZ EXH/EXHC boom on the bracket and secure with the hinch pin (RZ EXH/EXHC). Attach the loose end of the shorter connection cable to the arm. Fit the tie strap in hole and in the anchor.

Use the attachment that is dimensioned for the weight of the arm. Also check that the bearing capacity of the wall or ceiling is adequate.

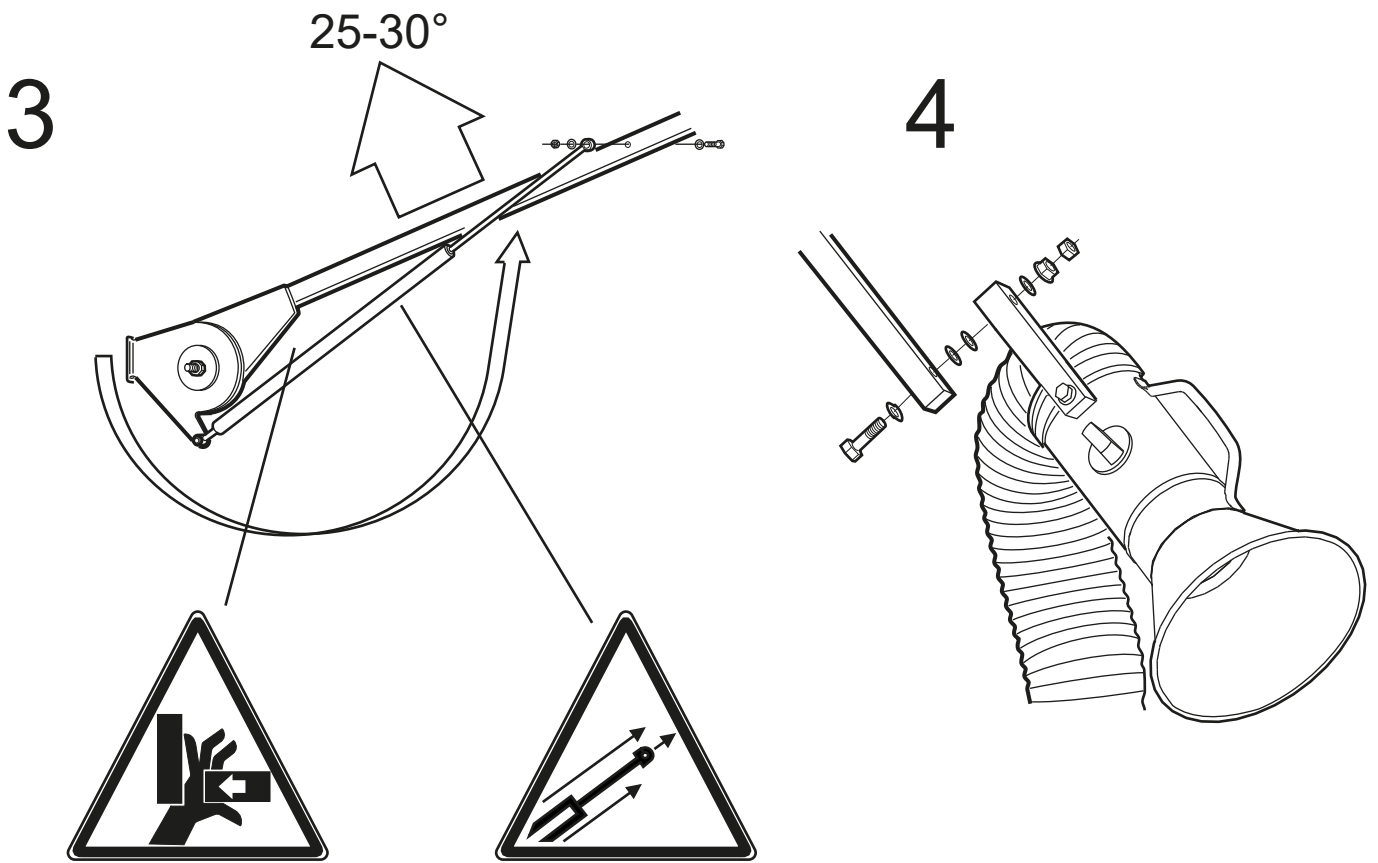

3) Fit gas spring.

4) Fit suction head.

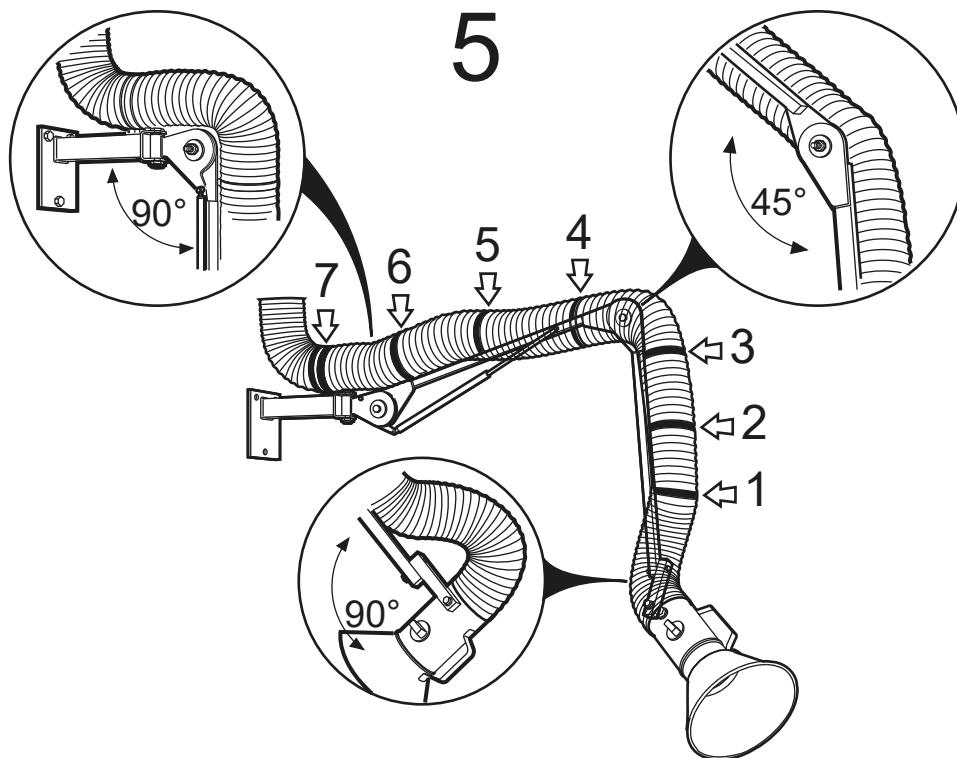

5) Ensure that the hose is long enough to enable full mobility over the joints, and stretch the hose over the long sections before tightening the mounting strap in the correct order starting with the suction head.

6

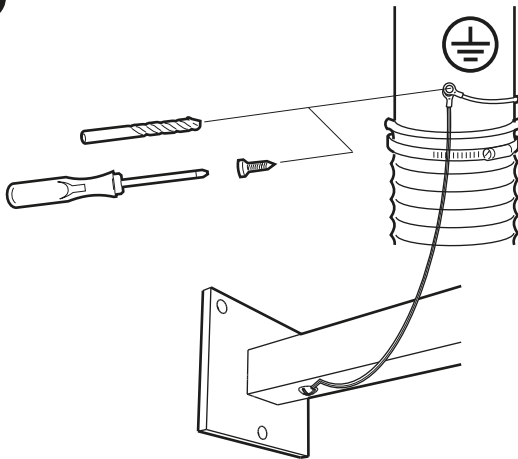

7

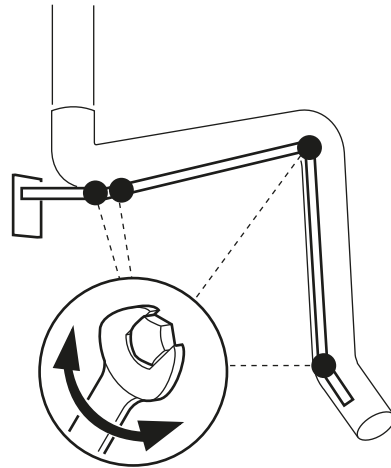

6) Secure the hose to the existing air duct with the accompanying clamp and screw the hose's earth connection to the air duct. Ensure that proper electrical contact is made.

Connect the earth cable on the bracket to a suitable connection point with the earthing system of the installation.

Important: Take the appropriate action if a risk of corrosion has been assessed at the connection point.

7) Tighten the friction joints to an appropriate torque allowing the extraction arm to be easily set and retain its set position without dropping. Where applicable, check that the earth cables across the joints move freely in all directions and that there is no risk of them getting caught in the arm or other objects.

Important: Prior to initial operation, the resistance of the arm must have been measured at a satisfactory value as per "Testing and troubleshooting" and the connection to the earth system must have been checked.

Dismantle in the reverse order. Open the tie wraps by releasing the catches in the bushing while tightening the strap. If the equipment is dismantled and the tie wraps cannot be reused for assembly, fit new, original tie wraps. Ensure that the earth connections to the hose are not damaged when dismantling.

Place the suction head as close to the worksite as possible for the best effects. The extraction effect can be controlled using the damper where necessary.

NOTE:

Personnel working in environments where an explosive atmosphere may arise, as well as all other people that enter the area, must be aware of the risks involved.

- Ensure that sparks or objects that may give rise to sparks are not sucked in.
- Guard the suction head and supporting arm against impacts from hard objects.
- When extracting different kinds of dust in combination, start by ensuring that the mix is not ignitable, such as grinding dust from iron in combination with aluminium dust.
- Ensure that objects or people that may be electrostatically charged cannot come into contact with the equipment.
- Avoid charging of non-conductive dust.
- Avoid hygroscopic dust or dust that may stick
- Exercise caution where hybrid mixtures of gas and dust are involved, as they are more easily ignited than the safety data shows individually for the solvent and powder used.

Cleaning

Clean the extraction arm in the same way as the other equipment at the worksite, however, at least once a year.

Clean when there is no risk of explosion in the environment. Observe the risk of electrostatic discharge from people or cleaning tools where there are dust deposits. People are recommended to wear semi conductive shoes and suitable clothing when cleaning where there is dust with MIE < 30 mJ.

Wear respiratory protective equipment and other appropriate personal safety equipment when cleaning.

For dry cleaning: Vacuum and dry externally and internally where necessary.

For wet cleaning: Check that the solvent does not attack any of the material used in the equipment, see "Technical data". Observe manufacturer dosing instructions. Allow the equipment to dry before using again.

Hoses that need to be cleaned internally may have to be removed (see "Assembly, initial operation and use"). Clean dry or wet, let the components dry and fit them together again.

Remeasure the resistance to earth as per "Testing and troubleshooting" before using the extraction arm again.

Service and repairs

In addition to the routine cleaning, the equipment must be remeasured with respect to the resistance where necessary, or at least twice per year as per "Testing and troubleshooting". Remeasure each time the equipment is worked on.

You should check the connections at the earth lines, spiral hose and earth point at the same time as the resistance measurement in order to identify any corrosion or loose connections. This is particularly important if the equipment is used in damp or corrosive environments.

Carry out service and repairs when there is no risk of explosion in the environment. People are recommended to wear semi conductive shoes and suitable clothing when servicing where there is dust with MIE < 30 mJ.

Adjust the friction joints in the supporting arm where necessary or at least once a year.

Only use original spare parts when needed; see "Spare parts and accessories".

- | | |
|---------------------------|---|
| 1. Suction head | 32. Friction joint R 1500, R 2000, R 3000 |
| 2. Damper knob | 33. Screw |
| 3. Rubber washer | 34. Nut |
| 4. Damper blade | 35. Screw |
| 5. Nut insert | 36. Anchor |
| 6. Locking washer | 37. Screw |
| 7. Screw | 38. Hose strap |
| 8. Nut insert | 39. Wall bracket R |
| 9. Supporting washer | 40. Connection cable 0.6 m |
| 10. Nut insert | 41. Outer supporting arm RZ |
| 11. Nut | 42. Link arm RZ |
| 12. Flange nut | 43. Nut |
| 13. Thrust washer | 44. Screw |
| 14. Screw | 45. Inner supporting arm RZ |
| 15. Locking washer | 46. Connection cable 0.2m |
| 16. Link arm | 47. Wall bracket RZ |
| 17. Plastic plug | 48. Locking pin |
| 18. Screw | 49. Connection cable 0.35 m |
| 19. Clamps | |
| 20. Supporting arm, lower | |
| 21. Screw | |
| 22. Locking nut | |
| 23. Nut | 50. Ceiling bracket R |
| 24. Screw | |
| 25. Gas spring | |
| 26. Supporting arm, upper | 51. Ceiling bracket R, twin joints |
| 27. Hose | |
| 28. Locking nut | |
| 29. Ball bearing | |
| 30. Friction lining | |
| 31. Friction joint R 4000 | 52. Ceiling bracket RZ |

Accessories

TIX 500EX, TIX 500EXH
TIX 1000EX, TIX 1000EXH
TIX 1500EX, TIX 1500EXH

TIX 500/180EX, TIX 500/180EXH
TIX 1000/180EX, TIX 1000/180EXH
TIX 1500/180EX, TIX 1500/180EXH

TIZ 500EX
TIZ 1000EX
TIZ 1500EX

Always state the type designation and serial number when ordering spare parts or accessories.

Spare parts and accessories

Always state the type designation and serial number of the arm (see rating plate on arm), the number of required spares and the spare part name and number as per the list below, when ordering spare parts or accessories.

Ceiling brackets in EX design are available as accessories for R EXH/EXHC arms. Fit these according to the instructions in this manual; see "Installation and use". Never use any other accessories for R EXH/EXHC arms as this may jeopardise the explosion protection.

R EXH/EXHC

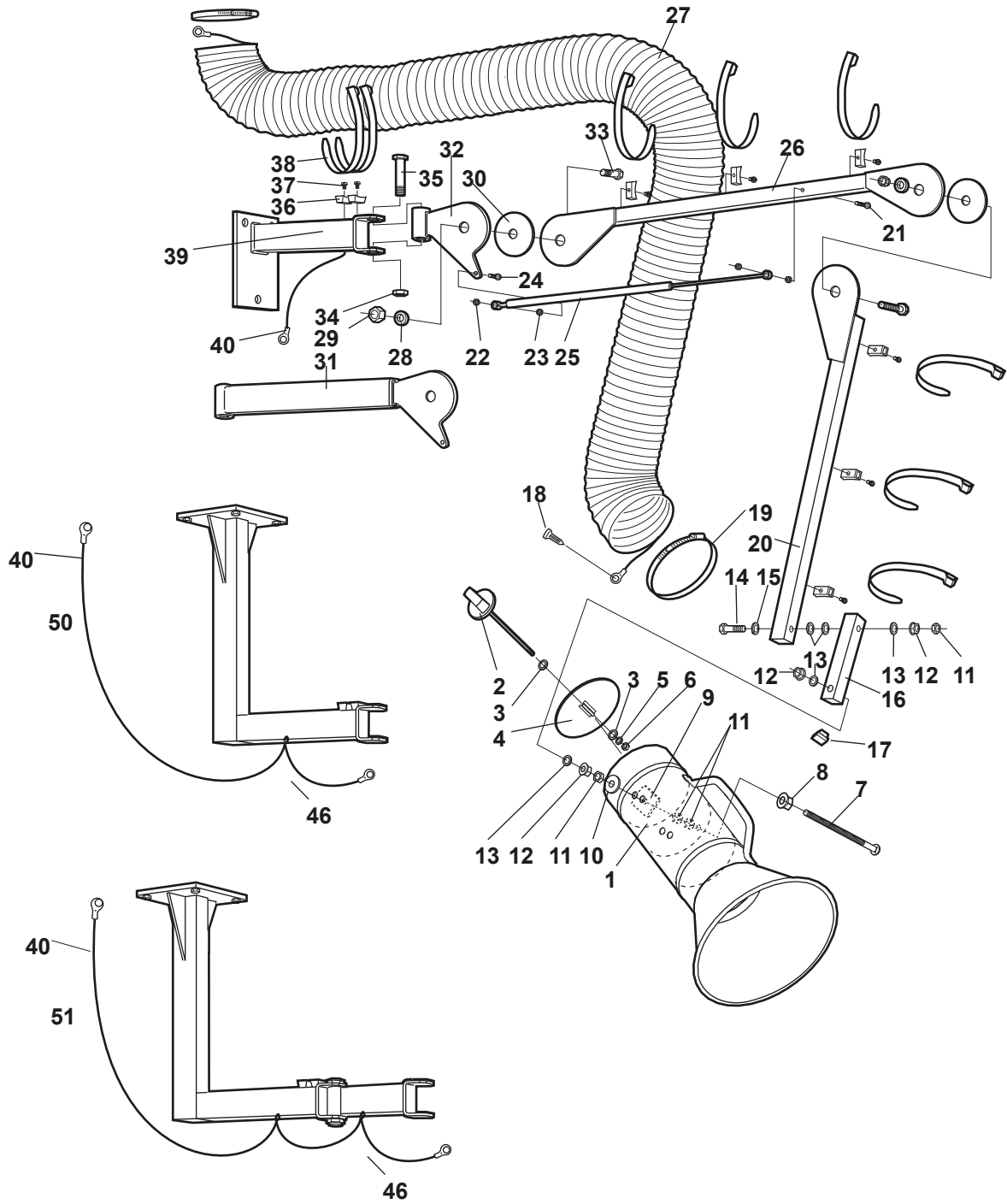

RZ EXH/EXHC

