



PSS

High-quality, acid-resistant extractor arm in stainless steel for stringent sanitary requirements



CLEANROOM
CERTIFIED



FOOD
GRADE



ATEX
COMPATIBLE

MOVEX

PURE ADVANTAGE

EASY CLEANING:

- High-gloss polished (Ra \leq 0,6) acid-resistant stainless steel
- **MOVEX Q-MaiD™** quick hose connection (suspension and attachment)
- Detachable protective grille
- Component-free airflow
- Fully sealed profile
- Few components for easy cleaning
- Food-grade certified hose
- Food-grade certified stainless steel gas spring
- Dual grounding for maximum safety



Fully stainless steel extractor arm for demanding work environments

MOVEX PSS - Cleanroom certified extraction arm with a smart and stylish design developed primarily for industries with strict hygiene requirements, such as the food and pharmaceutical industries. A design based on the fundamental Movex principle of using external support arms, which produce the lowest possible pressure drop and pose little risk of blockage. All surfaces finished in high-gloss polished acid-resistant stainless steel, and the antistatic hose is fitted with quick connectors, making PSS the most easily cleaned extraction arm in the industry. MOVEX PSS is available in lengths of 7', 10' & 14', and in 4", 5", 6" or 8" diameters.



Q quick
M maintenance
A assembling
I installation
D dismantling

What is MOVEX Q-Maid™?
MOVEX Q-Maid™ is a quick connection system that simplifies maintenance, assembly, installation and disassembly.



Cleanroom, ATEX, "Food Grade", fully sealed profile and few components in a unique combination

On the **MOVEX PSS**, both hose and gas spring are food grade, and the finish of the high-gloss polished steel is top class. In addition, the support arms have a fully sealed profile.

Other components are both non-toxic and few, which overall makes the work of keeping the equipment sanitary over time significantly easier than similar products on the market.

The extraction arm is ATEX compliant and meets the requirements of the ATEX directive for category 2 equipment for gas and dust, and it is suitable for use in zones 1 and 21 as well as 2 and 22.

Cleanroom certified

Cleanrooms are controlled work environments that require low levels of environmental contaminants such as dust, airborne microbes, aerosol particles and chemical vapors. This places high demands on equipment to be used in these environments.

MOVEX PSS is cleanroom tested and certified by a third party. The certificate means that MOVEX PSS meets the authorities' requirements and is an approved extraction arm for cleanroom-controlled work environments.

ATEX labelling

Movex ATEX-compliant extraction arms are labelled with a nameplate providing information on the explosive atmospheres for which the product is suitable. The nameplate is structured as follows:

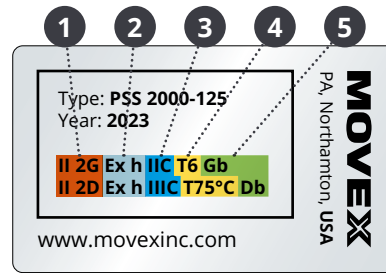

- 1 ATEX code
- 2 Type of protection (non-electrical)
- 3 Gas/Dust group
- 4 Temperature class
- 5 Equipment protection level

Equipment group 1

Group	Area
I	Below ground
II	Above ground

Type of protection (non-electrical) 2

Symbol	Type of protection
h	Protection through design safety non-electrical equipment

Equipment category

Group	Zone
M1	Energized
M2	Non-energized
1	Very high protection
2	High protection
3	Normal protection

Gas groups 3

Group	Example
I	Methane
IIA	Propane
IIB	Ethylene
IIC	Hydrogen

Temperature class gas 4

Class	Max. surface temp.
T1	842 °F
T2	572 °F
T3	392 °F
T4	275 °F
T5	212 °F
T6	185 °F

Equipment protection level 5

Level	Zone
Ga	0
Gb	1
Gc	2
Da	20
Db	21
Dc	22
Ma	Energized
Mb	Non-energized

Gas	Dust
G	D

Dust groups

Group	Example
IIIA	Combustible
IIIB	Non-conductive
IIIC	Conductive

Temperature class dust

Max. external surface temp.

ATEX

Zone classification

Potentially explosive areas or premises must be classified in zones according to the frequency of occurrence and duration of explosive atmospheres. The person responsible for the operations is responsible for ensuring the classification of such risk areas.

Classification shall be conducted by persons knowledgeable about the properties of any flammable goods, the process and the equipment. Classification can be conducted in consultation with protection and electrical engineers as well as process technicians.

Zone 0 and Zone 20

An area in which explosive atmospheres are present continuously, for long periods or frequently.

Zone 1 and Zone 21

An area in which explosive atmospheres are expected to occur during normal operations.

Zone 2 and Zone 22

An area in which explosive atmospheres are not expected to occur during normal operations but, if they do occur, only last for a short time.

Dimensional drawing (in)

PSS 2000/3000

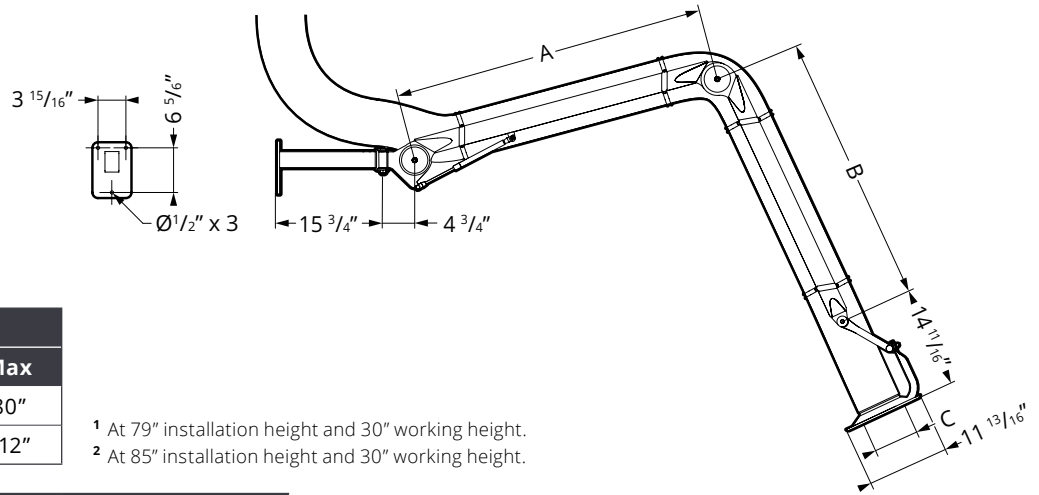

WORKING RADIUS (in)		
Model	Min	Max
PSS 2000 ¹	0"	80"
PSS 3000 ²	0"	112"

¹ At 79" installation height and 30" working height.
² At 85" installation height and 30" working height.

DIMENSIONS (in)			
Model	A	B	C
PSS 2000	25 9/16"	29 1/2"	Ø 4 / 5 / 6 / 8"
PSS 3000	45 1/4"	39 3/8"	Ø 4 / 5 / 6 / 8"

PSS 4000

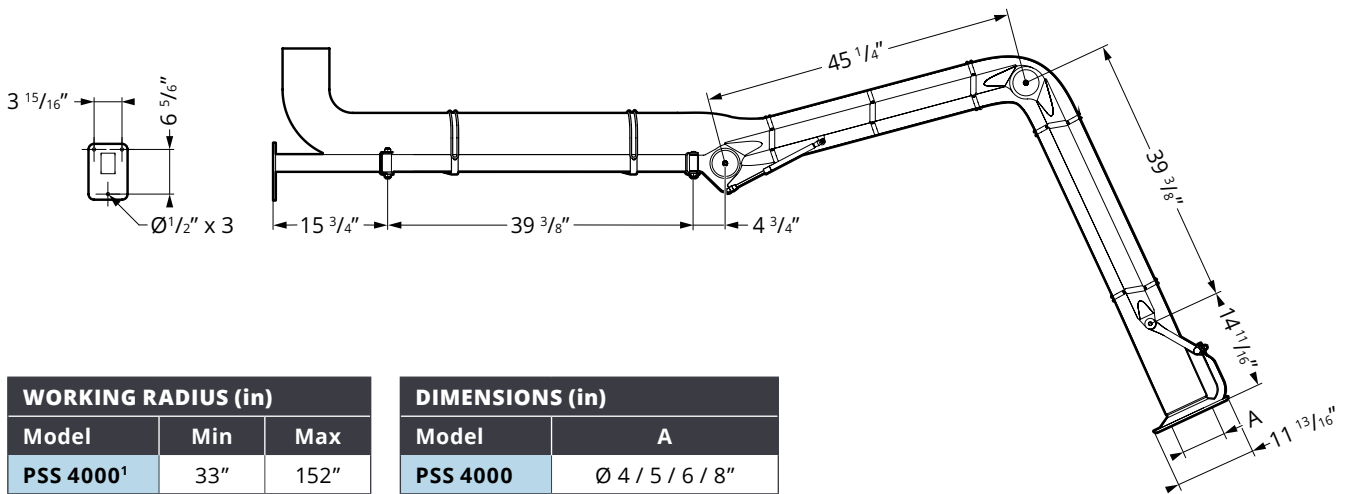

WORKING RADIUS (in)		
Model	Min	Max
PSS 4000 ¹	33"	152"

DIMENSIONS (in)	
Model	A
PSS 4000	Ø 4 / 5 / 6 / 8"

¹ At 85" installation height and 30" working height.

Pressure drop diagram

PSS Ø4"

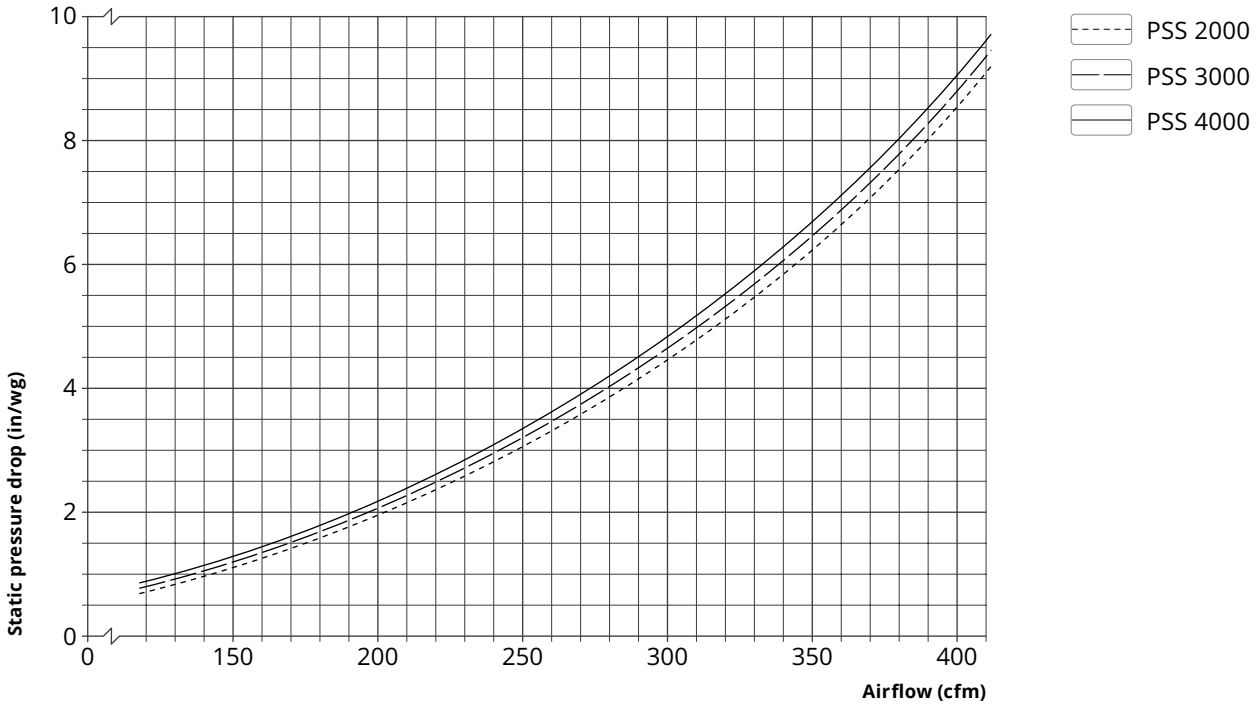

PSS Ø5"

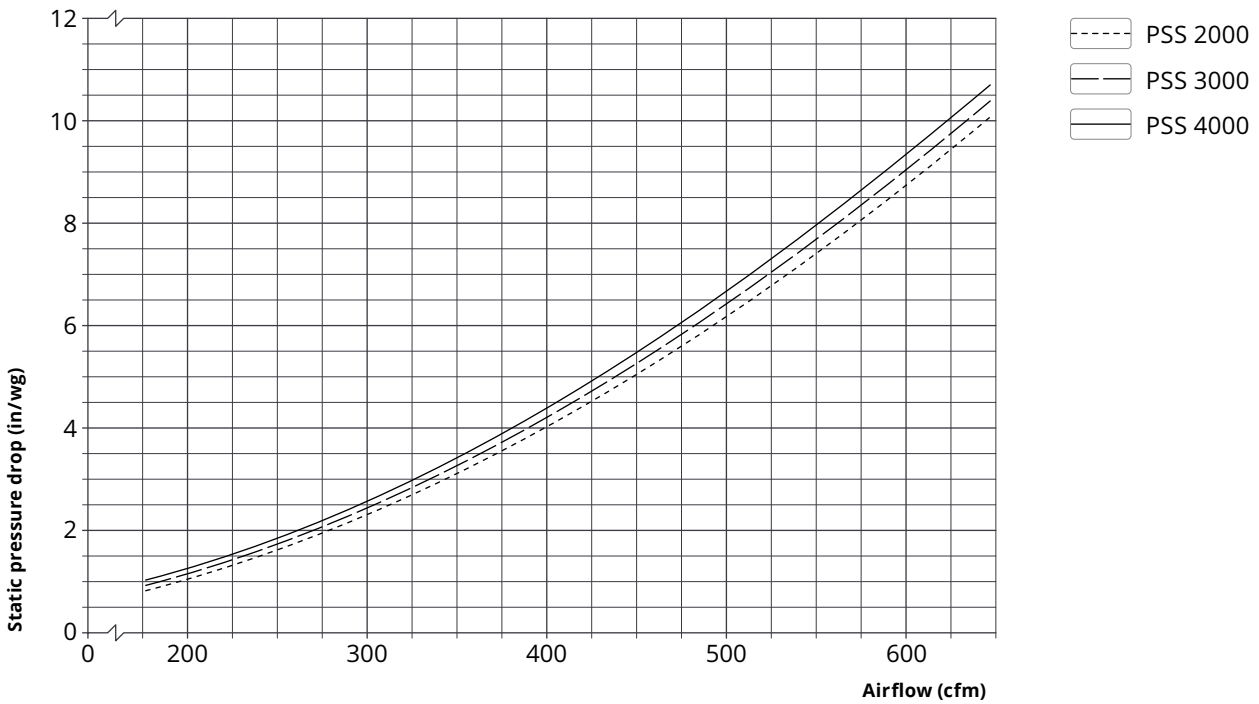

PSS Ø6"

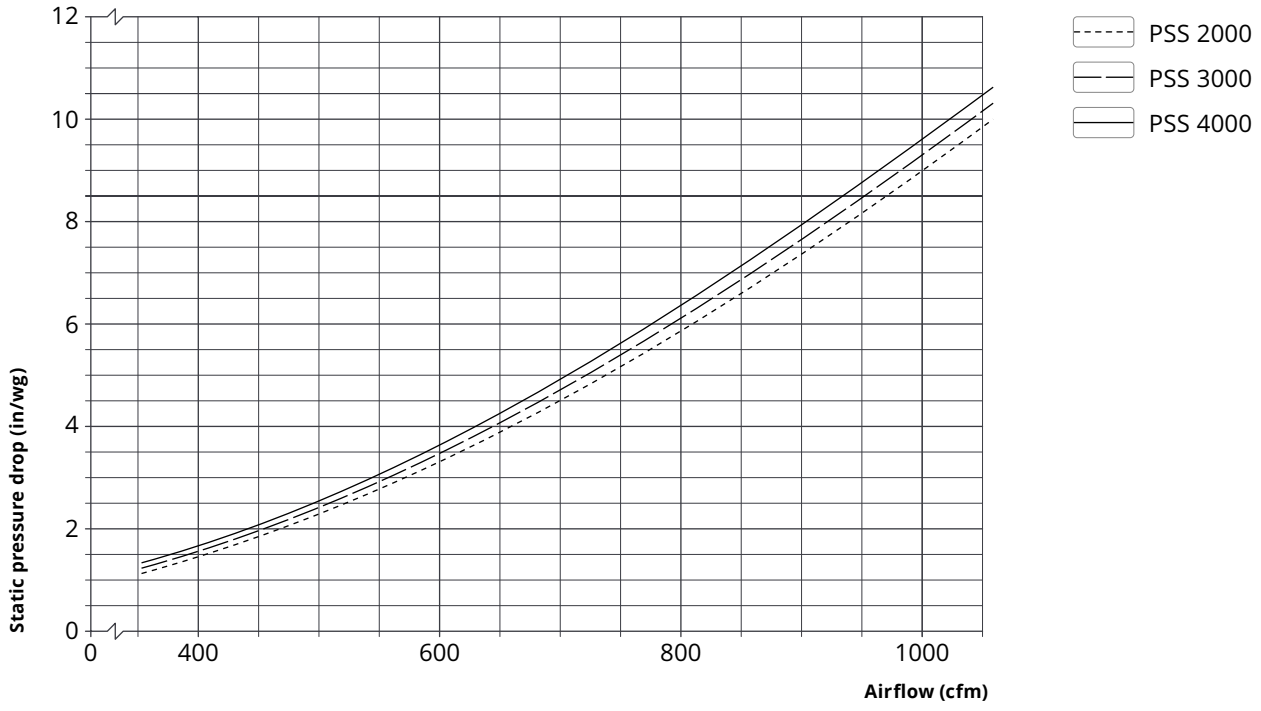

PSS Ø8"

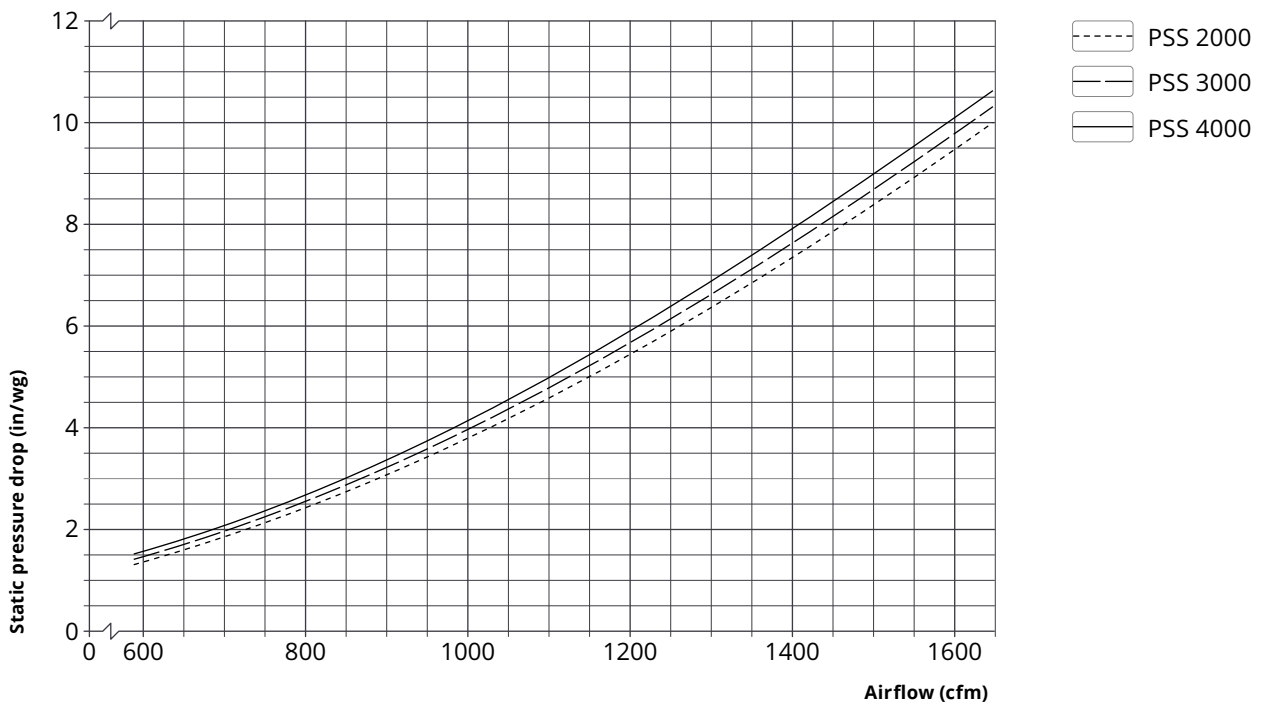

Accessories



Ceiling bracket PTA4
Ceiling bracket in acid-resistant stainless steel.

Lengths:
20 / 40 / 60"



Floor bracket PGA4
Floor bracket in acid-resistant stainless steel.

Length:
87"



Rotation link PLA4
Extension link in acid-resistant stainless steel for 180° of additional rotation.

Length:
9"



Damper PSMS¹
Damper in acid-resistant stainless steel. Easy to assemble/disassemble for quick and easy cleaning.

Dimensions:
Ø4 / 5 / 6 / 8"

¹ The damper must be factory installed to guarantee the function of the earthing.

Specifications

Form of delivery

The extraction arm is delivered partially assembled with a wall bracket for easy installation.

Production

Since the product does not have an internal ignition source, it cannot be certified under the ATEX directive 2014/34/EU.

Certificate

Cleanroom certified (TÜV SÜD, certificate no.: 3801499-00), Class ISO 6 according to DIN EN ISO 14644-1 (corresponds to GMP class C regarding the particle sizes). The certificate is limited to air cleanliness by particle concentration.

Surface treatment

Structural components and hood: High-gloss polished Ra ≤0,6 acid-resistant stainless steel (A4), grade EN 1.4401 / AISE 316
Plastic components:PP, PA6, TPU (FDA)
Rubber components:EPDM (FDA)

Versions

PSS	2000	3000	4000
Length (ft):	7	10	14
Weight ¹ (lb):	22,3	24,7	35,7

Hose

Properties:Permanent antistatic PU hose with stainless steel coil, R <10⁹ Ω
Temperature range: ... -40 °F to +212 °F
Dimensions (Ø):4 / 5 / 6 / 8"

Resistant to hydrolysis and microbes, non-toxic, and food-grade certified in accordance with EC Regulation No. 1935/2004 and No. 10/2011, FDA standards 21 CFR 177.2600 and 178.2010.

¹ Excluding hose.