

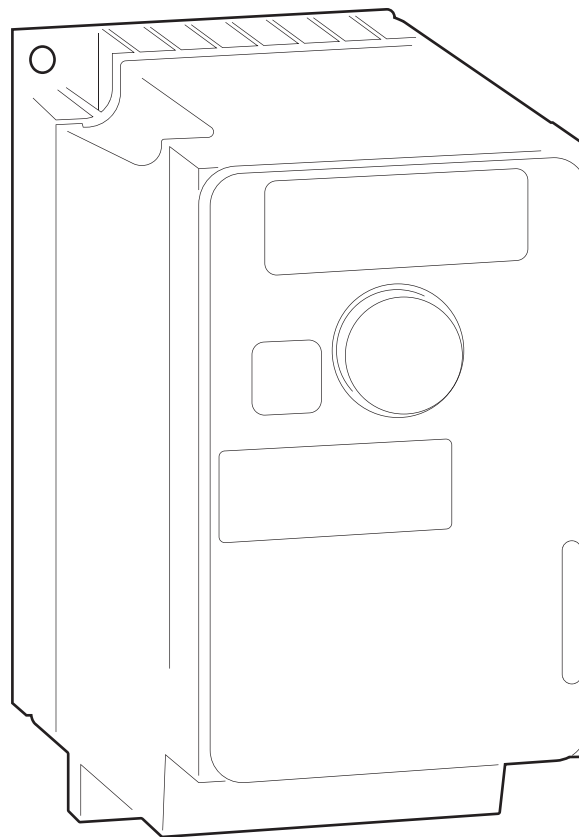

Programming manual

SFC

ST 300
0.75-15 Hp



General

This manual is a quick aid for easy programming of the frequency converter together with the pressure transmitter **ST 300** and shall not be seen as a complete product manual.

Function

All programming is executed on the keys at the front display **Fig. 1**. The jog dial (1) is used for navigating the menus and to select or confirm information. The ESC key (2) quits a menu/ parameter or clears and reverts the value. The front panel is opened via button (3).

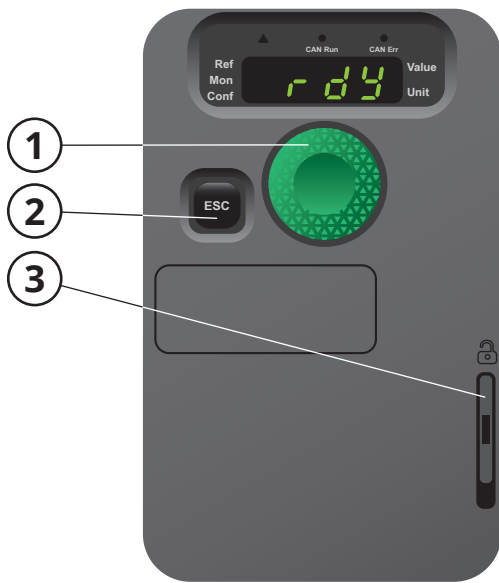

Fig. 1

Parameter choice

For parameter choice, see **Fig. 2**.

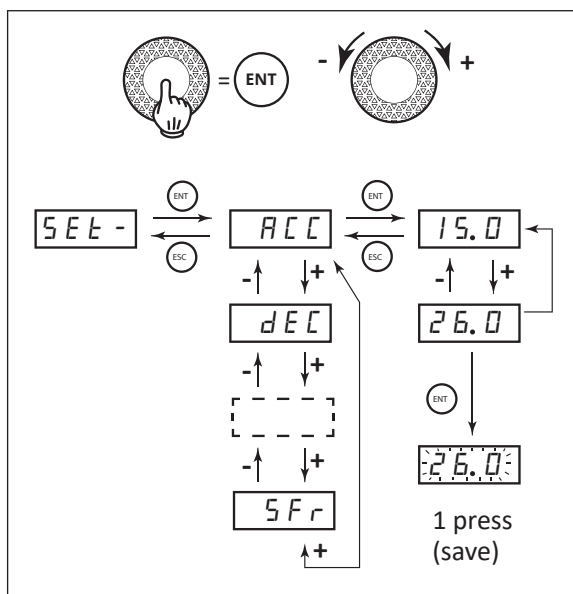

Fig. 2

Electrical wiring

The supply voltage is connected to terminal (6) **Fig 3**. The supply cable for the fan motor is connected to terminal (7). The start signal is wired between DI1 and +24 at terminal (8). The signal from the pressure transmitter is wired between COM, AI1 and +24 at terminal (8, 9).

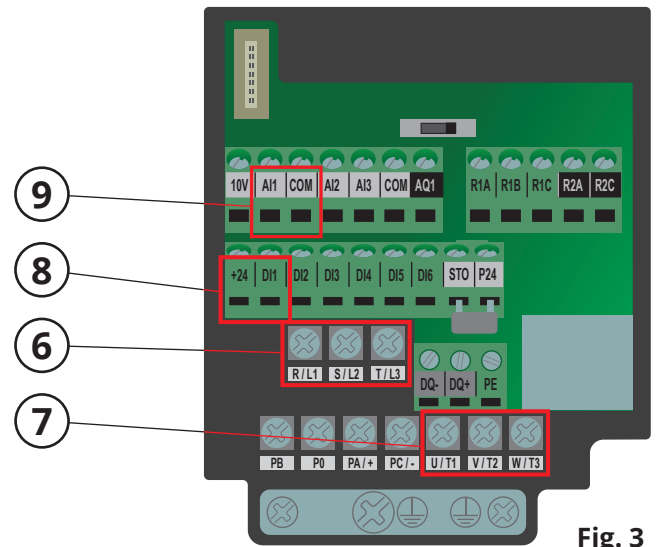
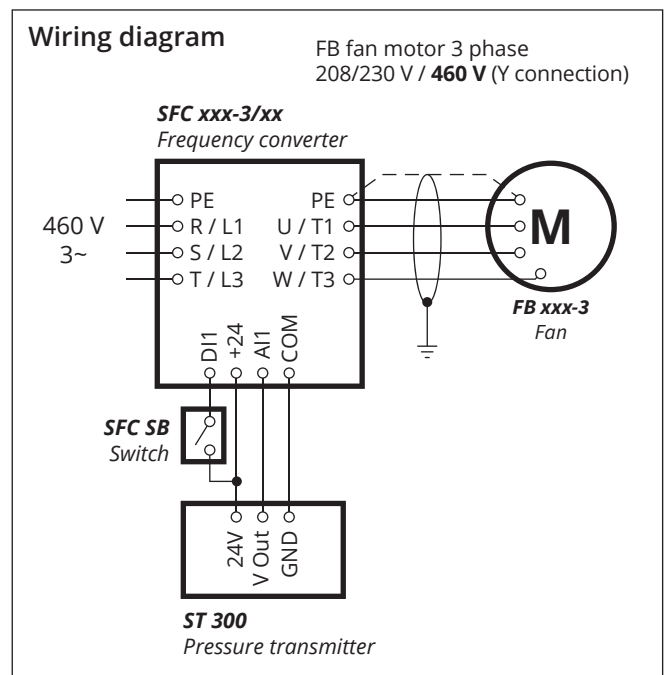

Fig. 3



Programming

Program all parameters as per the programming guide, see page 3. Start from the top (and go down) accordingly. During the programming, the fan must not receive any start signal. This means that DI1 and +24 (8) cannot be a closed circuit.

Note! The green parameters can be changed, to optimize current system. The red parameters can be found on the motor. The blue parameter "rPl" indicates desired pressure in the exhaust air duct. Please check value on pressure transmitter **ST 300**.

PROGRAMMING GUIDE						
Menu	Sub menu	Parameter	Function	Factory settings	Recommend. value	Chosen value
ConF	FULL	-	Access to configuration	-	-	
drC-	CtC	-	Variable torque	Std	UF9	
CtL-	Fr1	-	Change of reference source	All	R12	
SI n-	-	bFr	Motor frequency (Hz)	60	60	
SI n-	-	UnS	Nominal motor voltage (V)	-	Varies	
SI n-	-	FrS	Nominal motor frequency (Hz)	600	Varies	
SI n-	-	nCr	Nominal motor current (A)	-	Varies	
SI n-	-	nSP	Nominal motor speed (rpm)	1400	Varies	
SI n-	-	ACC	Acceleration (s)	30	50	
SI n-	-	dEC	Retardation (s)	30	50	
SI n-	-	LSP	Min. frequency (Hz)	00	150	
SI n-	-	HSP	Max. frequency (Hz)	600	600	
SI n-	-	IEH	Thermal motor protection (A) = motor current	-	Varies	
drC-	RSY-	PPC	Motor parameter choice	nPr	C05	
drC-	RSY-	C05	Motor's Cos Phi	-	Varies	
drC-	-	SFr	Switch frequency (kHz)*	40	16	
I_0-	-	CtC	2 wire type	Ern	LEL	
FUn-	StC-	StC	Stop type	StC	nSt	
FUn-	Pld-	PIF	Regulation feedback	n0	All	
FUn-	Pld-	PII	Internal PI reference	n0	YES	
FUn-	Pld-	PIF1	Min PID feedback	100	100	
FUn-	Pld-	PIF2	Max PID feedback	1000	2000	
FUn-	Pld-	PIP2	Max PID reference	900	2000	
FUn-	Pld-	rPl	Internal desired value for PI regulator (Pa)	150	**	
FUn-	Pld-	rPB	PI proportional amplifier	100	185	
FUn-	Pld-	rIB	PI integral amplifier	100	020	
FLt-	FLr-	FLr	Soft restart	n0	YES	

* Only to be changed when there is unusual noise from the motor.

** 500 Pa for laboratory extraction, 1500 Pa for industrial and exhaust extraction.

Default reset

When resetting to the factory settings, please proceed as below:

If the display doesn't show **rd4**, press **ESC** until it does. Enter menu **ConF** and select parameter **FE5-**. Change the value from **FE51** to **Fr4-**, confirm with **ENT**. Change **ALL** to **ALL'** by pressing **ENT**. Go back one step in the menu with **ESC** and change from **Fr4-** to **BF5**. Press **ENT** and change **n0** to **YES** by pressing and holding **ENT** for 5 s.

The frequency converter will now have the initial factory settings and is ready for programming again.

Troubleshooting



Troubleshooting when power is on, should only be performed by an authorized electrician.

Information to identify potential problems can be found in the troubleshooting guide. Always go through the troubleshooting guide before contacting MOVEX.

TROUBLESHOOTING GUIDE		
Symptom	Probable cause	Recommended measure
1. Programming failure.	DI1 and +24 are closed.	Remove wiring.
	The parameters are not programmed in the correct order.	Program the parameters, as per the programming guide from the top to the bottom.
2. The system does not work.	The wiring is not done as per the wiring diagram.	Check the wiring.
3. Performance loss of the fan.	Wrong rotation direction of the fan.	Check rotation direction.